

# 1,000 PSI FULL PORT 3-PIECE BALL VALVE



## DESCRIPTION

Floating Ball, Three-Piece Bolted Body Design  
 Swing-Out Body for In-Line Maintenance  
 Full Port, Anti-Blow-Out Stem, Lever Operated  
 Socket Weld Ends to ANSI B16.11  
 Locking Device Optional  
 Also Available in Threaded Ends

DPV® Fig. 3F133S

Temp.	Pressure Rating	Temp.	Pressure Rating
Cold	1,000 psig @ -20 to 100 °F 69 barg @ -29 to 38 °C	Max.	150 psig @ 365 °F 10 barg @ 185 °C

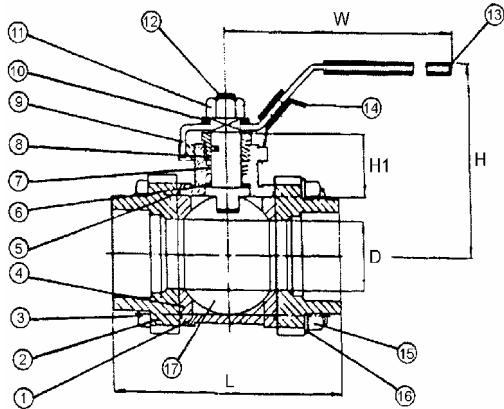
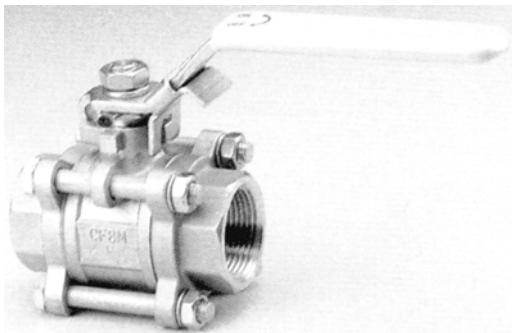

Major Components

Item	Part	Material
1	Body	S.S. ASTM A351 Grade CF8M
2	End Piece	S.S. ASTM A351 Grade CF8M
3	Bolt	304 Stainless Steel
4	Seat	Virgin PTFE
5	Seal	Virgin PTFE
6	Thrust Washer	Virgin PTFE
7	Packing	Virgin PTFE
8	Gland	304 Stainless Steel
9	Lever	304 Stainless Steel
10	Stem Washer	304 Stainless Steel
11	Stem Nut	304 Stainless Steel
12	Stem	316 Stainless Steel
13	Sleeve	Plastic
14	Locking Device	304 Stainless Steel
15	Hex Nut	304 Stainless Steel
16	Washer	304 Stainless Steel
17	Ball	316 Stainless Steel

Dimensions and Approximate Weights

Size		L		ØD		H		H1		W		Cv	K	Approx. Wt.	
in	mm	in	mm	in	mm	in	mm	in	mm	in	mm	gpm		lb	kg
¼	8	2.36	60	0.46	11.6	2.24	57	0.51	13	3.78	96	8	0.61	0.9	0.39
½	15	2.95	75	0.63	15.9	2.68	68	0.71	18	4.88	124	15	0.61	1.5	0.70
¾	20	3.15	80	0.81	20.6	2.76	70	0.71	18	4.88	124	30	0.43	2.0	0.92
1	25	3.54	90	1.00	25.4	3.15	80	1.14	29	5.59	142	45	0.44	2.7	1.21
1¼	32	4.33	110	1.25	31.8	3.31	84	1.14	29	5.59	142	80	0.34	3.9	1.76
1½	40	4.72	120	1.50	38.1	3.66	93	1.14	29	7.95	202	120	0.31	6.2	2.79
2	50	5.51	140	2.00	50.8	3.94	100	1.14	29	7.95	202	240	0.25	10.1	4.56
2½	65	7.28	185	2.56	65.0	5.59	142	1.65	42	9.84	250	320	0.37	17.4	7.90
3	80	8.07	205	3.15	80.0	6.10	155	1.38	35	9.84	250	600	0.24	28.2	12.8
4	100	9.45	240	3.94	100	6.77	172	1.38	35	11.81	300	900	0.27	49.6	22.5

All above specifications are for informatory purpose only, and are subject to changes without prior notice.

DELTA PACIFIC VALVE MFG. CO., New York, U.S.A.